

GENERAL INFO

DESIGNED FOR CARAVANS, CAMPER & RVs

Compact Caravan/RV Inline Undersink Filter System with LED Faucet

The CR-Z2 is a compact system designed specifically for applications where there is limited under-bench space; perfect for caravans and RVs. It's compact design makes it easier to install where space is limited, installs very easily & mounts horizontally or vertically so no shelf cutouts are required. The CR-Z2 features Z Plus Filtration Technology through an advanced 3 stage filtration process; filtering down to 1 micron* removing chlorine, chemical, sediment, rust, and algae - helping to ensure you only get healthy, great tasting water on tap, wherever you go. It features an LED filter tap that turns from blue to red when the filter cartridge needs replacing.

FEATURES & BENEFITS

- Compact design makes it perfect for caravan/RV installations or where space is limited.
- Connects to 12 mm tubing.
- Specifically designed for mains, rain, harsh and rural water supply.
- Sediment, dirt, rust and other particles filtered down to 1 micron*.
- Provides pure, safe, filtered water, free of chlorine.
- Use anti-bacterial beads to inhibit bacterial growth within the system.
- Incorporates Anti-scaling protection.
- With the introduction of Z Plus Technology, this Z2 cartridge has the ability to inhibit bacterial growth.
- Dedicated filter tap & standard caravan/RV fittings included.
- Valve-in-head means a DIY, no mess filter change.
- Quick and easy installation. Mounts horizontally or vertically - no shelf cutouts required.
- LED light that turns from blue to red when the filter needs replacing.



SPECIFICATIONS

Model Number:	CR-Z2
Replacement Cartridge:	Z2-R
Flow Rate:	5 Lpm
Min/Max Temperature:	0 - 38°C (protect from freezing)
Min/Max Pressure:	200 - 500 kPa
Micron Rating:	1 micron*
Capacity:	38,000 litres
Approx. Space Required:	
Vertical Mounting:	290 mm (h) x 90 mm (w)
Horizontal Mounting:	90 mm (h) x 290 mm (w)
Warranty:	10 years^

*Important Note: Use only genuine Puretec replacement cartridge. *10 year warranty is 1 year parts and labour, plus 9 years parts only. Excludes cartridges. *Micron Rating is nominal.*

INSTALLATION DIAGRAM

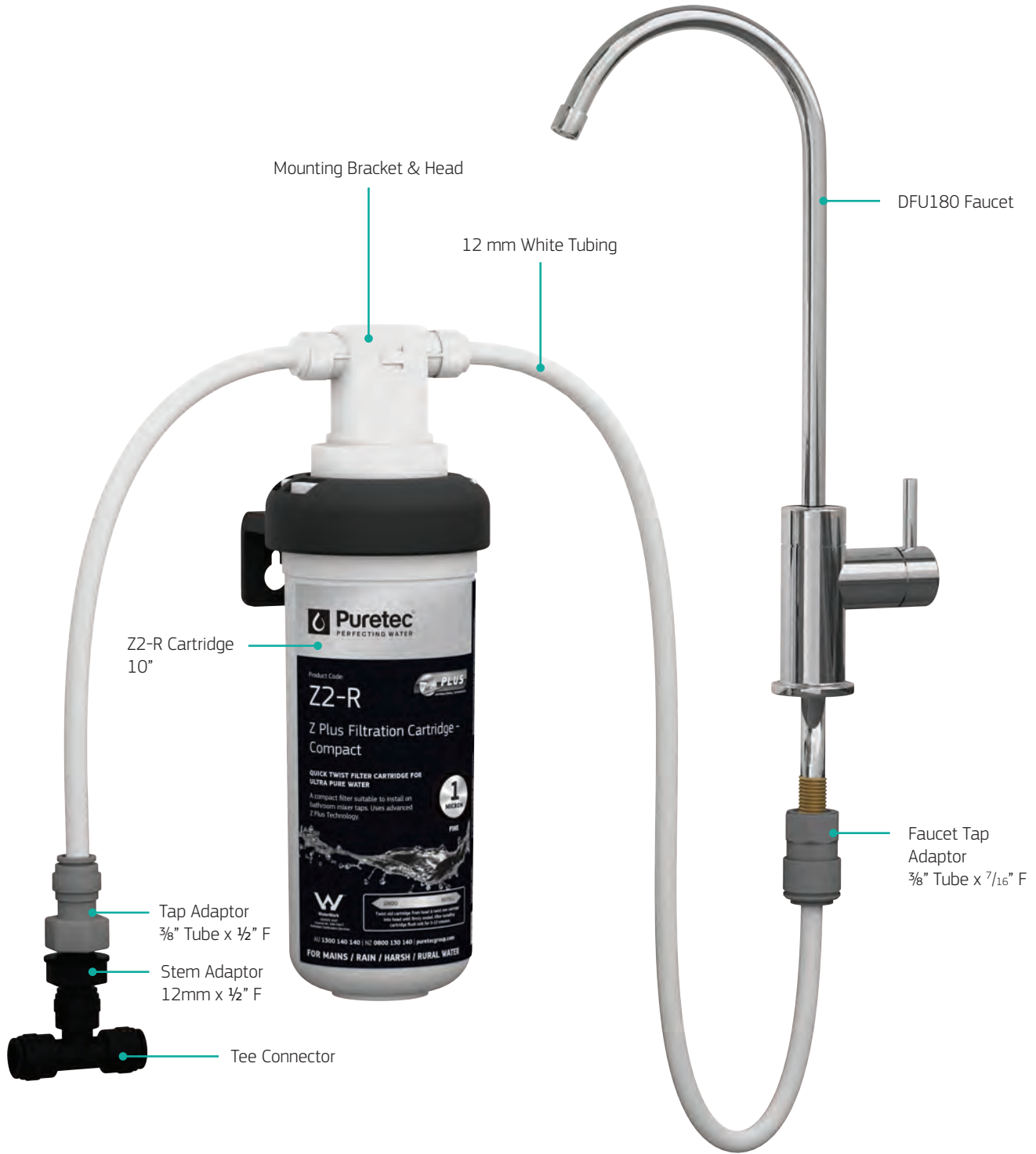

ADDITIONAL INFORMATION

Designed to reduce harmful Cryptosporidium & Giardia cysts, rust, dirt, sediment, chlorine, algae and chemicals leaving beautiful fresh drinking water.

Easy Installation

This premium filter system easily fit under your caravan, camper or RV kitchen bench. All plumbing fittings are included connect to 12mm tube commonly used in caravans and RVs for easy installation. It comes with a designer faucet with LED that turns from blue to red when the filter needs replacing.

Hygienic Quick Cartridge Changes

The valve-in-head design shuts the water off automatically, which means no mess, the cartridge can be easily replaced - just like changing a light globe. Enjoy water the way it should be, abundant, clear and beautiful tasting no matter how remote the location of your camping adventures are!

Z PLUS FILTRATION TECHNOLOGY



Stage 1

- Removes particles.
- Clarifies the water.
- Removes sediment, rust, sand, silt & algae filtering down to 1 micron.

Stage 2

- Reduces chlorine and other chemicals.
- Eliminates bad taste and odours.

Stage 3

- Anti-bacterial technology inhibits bacterial growth within the system.
- Incorporates Anti-scaling protection.



PRODUCT DIMENSIONS Measurements in Millimeters (mm)

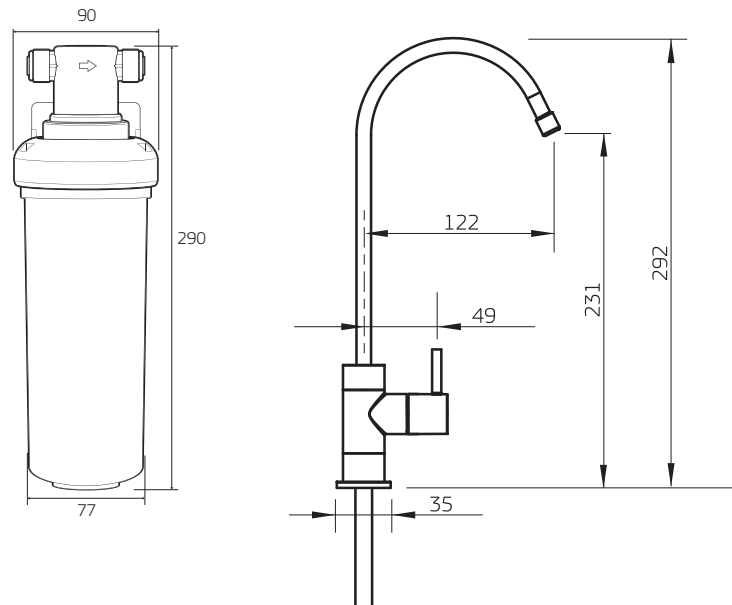

Note:
 1. No claims can be made based on the specifications and images in this document. The design, technology, colours, features and prices are subject to change.
 2. This document and all its contents are copyright protected. All rights are reserved, particularly alteration, translation and reproduction using electronic systems.
 3. ^Warranties in this document cover parts for the period stated and include cover for parts and labour for the first year where applicable, subject to approval. Plus 9 years parts only. Our Water Filtration Specialists can provide you with advice to suit your needs.

For more information contact your local stockist or visit us at puretecgroupp.com
 Australia **1300 140 140** | New Zealand **0800 130 140**